

I2C-Twin Relay

BV4502

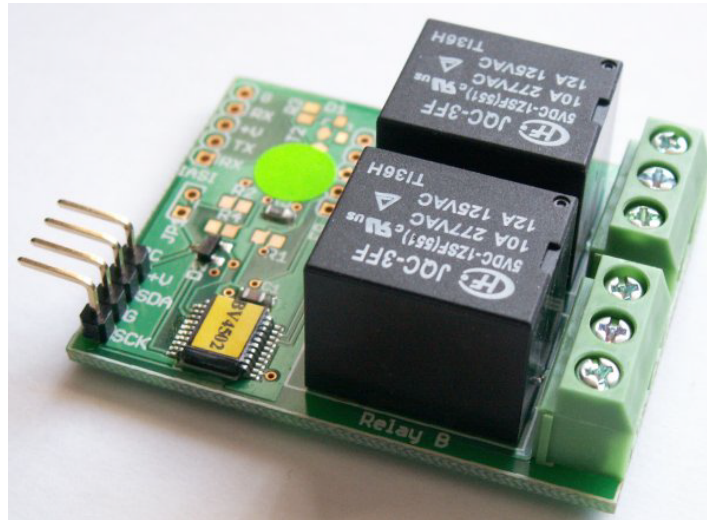

BV4502

I2C Twin Relay

Product specification

December 2008 V0.a

I2C-Twin Relay**BV4502****Contents**

1.	Introduction	3
2.	Features	3
3.	Electrical Specification	3
4.	Factory Reset	3
5.	I2C Command set.....	3
5.1.	Command 1	4
5.2.	Command 2	4
5.3.	Command 3	4
5.4.	Command 4	5
5.5.	Command 5	5
5.6.	Commands 6 to 8	5
6.	System Commands	6
6.1.	0x55	6
6.2.	Command 0x90	6
6.3.	Command 0x91	6
6.4.	Command 0x93	6
6.5.	Command 0x94	6
6.6.	Command 0x95	7
6.7.	Command 0x98	7
6.8.	Command 0x99	7
6.9.	Command 0xA0	7
7.	Hardware Reset.....	7
8.	Command Diagrams.....	7
8.1.	Sending a single command	7
8.2.	Sending a command with a parameter byte/s	8
8.3.	Receiving bytes from the salve	8
9.	Trouble Shooting	8
9.1.	Pulse Stretching	8
9.2.	Last Read NACK	8
9.3.	Pull Up's	8

I2C-Twin Relay

BV4502

Rev	Change
Jan. 2009	Preliminary

1. Introduction

The BV4502 is a twin relay that works with the standard I2C interface, this means that 'heavy' circuits can be controlled via a microcontroller with ease and without taking up any ports or MPU resources.

Default I2C address is 0x62

There is also an IASI version available part number BV4501.

2. Features

- I2C interface up to 400kHz
- SPDT relays Switched 5A DC and 10A AC
- 5V supply
- Power 2.4mA – no relays on
- Power 50mA 1 relay
- Power 94mA 2 relays
- Timed on/off delays
- Screw terminals for external equipment
- Size 50mm x 40mm x 17mm

3. Electrical Specification

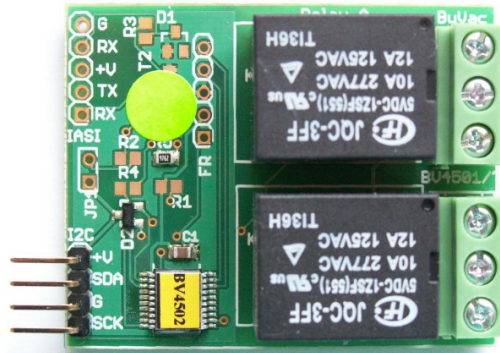

The relay board has 4 pins for the I2C interface, Clock, Data, +V and Ground.

Pull up resistors are required for the I2C interface, these are not provided on the relay board. The board is also used for the IASI2 interface and so any other holes should not be used.

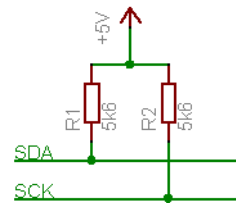

Figure 1 I2C Bus pull up resistors

Outputs from the relays are shown in Figure 2. At switch on the normal condition is for the relays to be off.

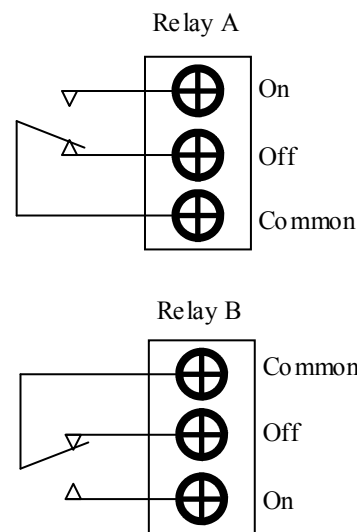

Figure 2 Terminal Connectors

4. Factory Reset

As the I2C address is stored in EEPROM and is fully configurable, it is possible that the user may forget what the address is. To restore factory defaults do the following:

- 1) remove power
- 2) Connect the square hole marked FR to the hole next to it, this will in fact connect the square hole to +V
- 3) Apply power
- 4) Remove power

The address and any other parameters that may be stored in the first half of the EEPROM will now be reset.

In general the first 16 bytes of EEPROM are normally reserved for system use but these areas can still be overwritten by the user.

5. I2C Command set

The format used by this device consists of a command, this is a number, followed by other bytes depending on that command.

I2C-Twin Relay

BV4502

There are two type of command, those referring to the device and those referring to the system. The system commands enable changing of the device address etc.

Device default address is 0x62

Command	LCD Command Set
1	Relay A on/off
2	Relay B on/off
3	Relay A timed on
4	Relay A timed off
5	Relay A timer display
6	Relay B timed on
7	Relay B timed off
8	Relay B counter display
Command	System Command Set
0x90	Read EEPROM
0x91	Write EEPROM
0x92	Confirm Command Complete
0x93	End of EEPROM
0x94	Sleep mode
0x95	Reset
0x98	Temporarily change address
0x99	Change Device Address Permanent
0xA0	Firmware Version

Table 1 Relay Command Set

Command	System Command Set
0x90	Read EEPROM
0x91	Write EEPROM
0x92	Confirm Command Complete
0x93	End of EEPROM
0x94	Sleep mode
0x95	Reset
0x98	Temporarily change address
0x99	Change Device Address Permanent
0xA0	Firmware Version

Table 1 is a command summary of all of the device and system commands.

The method of writing to the device using the I2C protocol follows a consistent format, typically:

<S-Addr><Command><data..><Stop>

Where S-Addr is the start condition followed by the device address (0x62). Command is one of the commands given in the table. Data is one or more bytes and Stop is the stop condition.

Reading data requires a restart and this will be in the format:

<S-Addr><Command><R-Addr><data..><Stop>

The restart address will be one greater than the start address, thus if the start address is 0x62, the restart address will be 0x63. Again the data can be one or more bytes read from the device.

For more information about the command formats see section 8.

Each command will have its own format and is described in the following text. A start condition and address is always followed by a command.

5.1. Command 1

Name: **Relay A**

Format: <S-addr><1><1 or 0><Stop>

This command turns relay A either on or off. 1 is on and 0 is off. At reset the relay is in the off condition. This command overrides any timed mode commands and acts immediately.

5.2. Command 2

Name: **Relay B**

Format: <S-addr><2><1 or 0><Stop>

This command turns relay B either on or off. 1 is on and 0 is off. This command overrides any timed mode commands and acts immediately.

5.3. Command 3

Name: **Relay A timed on**

Format: <S-addr><3><Hbyte><Lbyte><Stop>

This command turns relay A on in n number of 200mS intervals. As an example if the relay is required to come on 1 minute after the command then (60 / 0.2 = 300) the delay would be 300.

This should be converted to hex and sent as two bytes so the command in this case would be

<S-addr><3><0x1><0x2c><Stop>

The number is a 16 bit value so the maximum delay is 65535 200mS intervals or just over 218 minutes (3.6 hours). No checking is made if the number entered is not within this range so unpredictable results will occur if a number is entered outside of this range.

I2C-Twin Relay

BV4502

5.4. Command 4

Name: **Relay A timed off**

Format: <S-
addr><3><Hbyte><Lbyte><Stop>

This command turns relay A off in n number of 200mS intervals. As an example if the relay is required to go off 30 seconds after the command then (30 / 0.2 = 150) the delay would be 150.

This should be converted to hex and sent as two bytes so the command in this case would be

<S-addr><3><0x0><0x96><Stop>

The number is a 16 bit value so the maximum delay is 65535 200mS intervals or just over 218 minutes (3.6 hours). No checking is made if the number entered is not within this range so unpredictable results will occur if a number is entered outside of this range.

5.5. Command 5

Name: **Relay A counter**

Format: <S-addr><5><R-
Addr><HByte><Lbyte><Stop>

The command is used for inspecting the state of the count, using commands 3 or 4 will set a counter that is decremented every 200mS, this command allows the contents of this counter to be read.

The value is read as two bytes with the first byte being the high byte.

5.6. Commands 6 to 8

These are the same as 3,4 and 5 but for relay B.

I2C-Twin Relay

BV4502

Rev	System Section Changes
Oct 2008	Preliminary
Dec 2008	Removed command 96

6. System Commands

The following section deals with system commands that are common to all I2C devices. Note that not all of these commands are available for all devices.

Command	System Command Set
0x55	Test
0x90	Read EEPROM
0x91	Write EEPROM
0x93	End of EEPROM
0x94	Sleep
0x95	Reset
0x98	Change Device Address Temporary
0x99	Change Device Address Permanent
0xA0	Firmware Version

Most but not all devices contain an EEPROM that can store data when the power is off. The first 16 bytes of the memory is reserved for system use and should not be changed by using these commands.

If the contents of the first 16 bytes are changed then, depending on the device unpredictable results may occur. A factory reset will put the contents back to normal. In some devices not all 16 bytes are used.

The rest of the EEPROM can be used by the user for any purpose.

6.1. 0x55

Name: **Test**

Format: < S-addr><0x55><start><R-Addr><Value..><NACK><Stop>

BV4221 Example

```
0x42>s 55 r g-3 p
```

The above command will return 1,2,3 if the device is connected and working correctly.

This command simply returns an incrementing value until NACK is sent by the master prior to stop. This can be useful for testing the interface.

It can be used for testing the presence or other wise of a device at a particular address.

It is also useful during the development stage to ensure that the I2C is working for that device.

6.2. Command 0x90

Name: **Read EEPROM**

Format: <S-addr><0x90><EE-Address><R-Addr><data...><Stop>

BV4221 Example

```
0x42>s 90 0 r g-3 p
```

The above will fetch 3 bytes from the EEPROM addresses 0, 1 and 2

This command will allow a single or several bytes to be read from a specified EEPROM address.

6.3. Command 0x91

Name: **Write EEPROM**

Format: <S-addr><0x91><EE-Address><data...><Stop>

BV4221 Example

```
0x42>s 91 10 1 2 3 p
```

The above write 1,2 and 3 to EEPROM addresses 0x10, 0x11 & 0x12

This command will write one or more, up to a maximum of 30 bytes at any one time, to be written to the EEPROM. Address 0 of the EEPROM is the device address and this cannot be written to by this command. A special command 0x99 is used for this purpose.

The first 16 bytes 0 to 15 are reserved for system use.

6.4. Command 0x93

Name: **End of EEPROM**

Format: <S-addr><0x93><R-Addr><data><Stop>

BV4221 Example

```
0x42>s 93 r g-1 p
```

Returns the address of the end of the EEPROM, normally 0xff

The system only uses a small portion of the first part of the EEPROM, the rest of the EEPROM can be used for user data or other purposes depending on the device. This command returns a single byte that will determine the last writeable address of EEPROM, normally 0xFF.

6.5. Command 0x94

Name: **Sleep**

Format: <S-addr><0x94><Stop>

BV4221 Example

0x42>s 94 p

This will put the IC into sleep mode. Any other command will wake the IC. Depending on the device this can be a considerable power saving.

6.6. Command 0x95

Name: **Reset**

Format: <S-addr><0x95><Stop>

BV4221 Example

0x42>s 95 p

Resets the device, this is equivalent to disconnecting and then connecting the power again.

6.7. Command 0x98

Name: **Change Device Address Temporary**

Format: <S-addr><0x98><New-Addr><Stop>

BV4221 Example

0x42>s 98 62 p

Changes the device address to 0x62, the device will revert back to 0x42 at reset.

This will change the device address with immediate effect and so the next command must use the new address. The address must be a write address (even number) Odd numbers will simply be ignored. The effect will last as long as the device is switched on. Resetting the device will restore the address to its original value. The address is stored in EEPROM location 0.

6.8. Command 0x99

Name: **Change Device Address Permanent**

Format: <S-addr><0x99><New-Addr><0x55><0xaa><Current-Addr><Stop>

BV4221 Example

0x42>s 99 62 55 aa 42 p

Permanently changes the device address to 0x62.

This command changes the address immediately (the next command will need to use the new address) and permanently (see hardware reset). The address must be a write address (even number) and follow the sequence exactly.

Permanent in this case means that the device will retain this address after power down, i.e. it is stored in EEPROM. Should anything go wrong the default address can be restored by using a hardware reset.

6.9. Command 0xA0

Name: **Firmware version**

Format: <S-addr><a0><R-Addr><byte><byte><Stop>

BV4221 Example

0x42>s a0 r g-2 p

This will return the two firmware bytes.

This simply returns two bytes that represents the firmware version.

7. Hardware Reset

A hardware reset has been provided should the device address be changed to some unknown value.

The method of restoring the factory defaults and thus the default device address is as follows:

- 1) Remove power
- 2) Hold the designated pin low or high or connect two pins together. The actual pins are device dependant and will be referenced in the sections above this text.
- 3) Apply power
- 4) Remove power
- 5) Remove shorting link

When power is now restored the device will have the default I2C address, normally 0x42.

8. Command Diagrams

To further explain the format of the commands this section has been provided. The design of the interface has been purposely kept simple and so there are only a few standard sequences required.

Key

- Master
- Slave
- S Start condition
- P Stop Condition
- A Acknowledge = 1
- N Not acknowledge = 0

8.1. Sending a single command

This is designated in the list as:

<S-addr><cmd><Stop>

This sequence is used for simple functions where no data is involved. The I2C sequence, using the default address is:

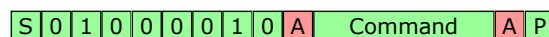

8.2. Sending a command with a parameter byte/s

This is designated in the list as:

<S-addr><cmd><data...><Stop>

Some commands expect a parameter after the command. In this case the bytes are sent one after the other up to the maximum of 31 bytes. The stop command tells the slave that there is a command ready to be executed.

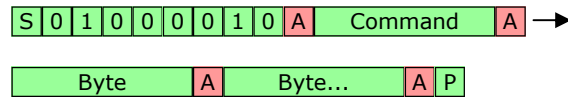

8.3. Receiving bytes from the slave

<S-addr><cmd-Addr><byte><Stop>

When receiving one or a number of bytes from the device a restart is required.

The command is sent with an even address (the R/W bit 0). When the slave acknowledges the command another start condition is sent with the R/W bit set to 1. This is called a restart. After this restart the slave will continue to send bytes until the master sends a not acknowledge (N or NACK).

If the master does not send a NACK at the last byte the slave will be expecting another byte to be requested and this may cause either unpredictable results or the I2C bus to lock.

9. Trouble Shooting

This section has been added to answer frequently asked questions. The problems are usually caused because the master device has not had the I2C specification fully implemented.

9.1. Pulse Stretching

This is a method of I2C handshaking which is used in BV slave devices but it is not always supported by the master system. The symptoms are erratic behaviour, some commands will be accepted and others will not.

To explain: when the slave device is busy it holds the clock line low (normally only the master controls the clock line), the master should check that the clock line is high before

sending the start condition. If it is low the master should wait until it is free.

Quite a few slave devices do not use pulse stretching and so this not being implemented in the master does not show up. However when dealing with relatively slow hardware, an LCD display for example (i.e. BV4219), this will become a problem. The work round is to make sure that the master recognises pulse stretching properly or introduce delays after each command.

9.2. Last Read NACK

When optionally multiple reads of a slave is required (the 0x55 command is a good example) the last read should send a NACK rather than a ACK. This informs the slave that no more reads from that command are required.

It has been found that some master implementations do not send a NACK on the last read. This causes the BV slave to remain in the (multi read) command effectively blocking any other commands.

The typical symptoms are that when the 0x55 command is implemented no other commands will work after that.

9.3. Pull Up's

The most common problem when trying to get a new device going is to forget to put the pull up resistors somewhere on the bus. BV Slave devices do not have pull up resistor on board so they must be provided by the master (the BV4221 has pull up's) or provided externally. A value of around 5k is okay but this is not usually critical.

